

TRAP STAR™ MODEL TSF-10•11 **STEAM TRAP**

PRODUCT MANUAL

Thank you very much for choosing the Yoshitake's product. To ensure the correct and safe use of the product, please read this manual before use. This manual shall be kept with care for future references.

The symbols used in this manual have the following meanings.



	Warning	This symbol indicates a potentially hazardous situation that, if not avoided, could result in death or serious injury.
	Caution	This symbol indicates a hazardous situation that, if not avoided, may result in minor or moderate injury or may result in only property damage.

Table of Contents

1. Usage of the Product	1
2. Features	1
3. Specifications	1
4. Dimensions and Weights	2
5. Operation	3
6. Maximum Continuous Discharge Capacity	4
7. Installation	5
7.1 Piping example	5
7.2 Precaution for installation	7
8. Operating Procedure	10
8.1 Precaution for operating procedure	10
9. Maintenance	11
9.1 Precaution for maintenance	11
9.2 Daily and periodic inspections	12
9.3 Troubleshooting	13
9.4 Exploded drawing	14
9.5 Disassembly	15
9.6 Reassembly	17
9.7 Parts replacement procedure	20
Warranty Information	

1. Usage of the product

The TSF-10, TSF-10F, TSF-11, and TSF-11F can discharge condensate effectively without retention, and realize energy saving steam system without steam loss. In addition, incorporated thermostatic air vent discharges air inside the piping and shortens warming-up time. So, the product is suitable for steam equipments used in various industries such as air-conditioning equipment, hot-water supply equipment, plant, and food.

2. Features

1. With turning the cock, it is possible to meet all flow directions (360 degrees) including horizontal or vertical installation. Flow direction can be switched easily without disassembly such as detaching the cover.
2. Since the main parts are installed on the cover and it is possible to disassemble the cover with the body installed on the piping, inspection and parts replacement can be conducted easily.
3. Compared to mechanical steam traps such as conventional float type or bucket type, the lower part (dimension from the connection to the bottom) of the product is shorter. So, the product can be installed in a low place such as condensate piping on low-floor equipment.

3. Specifications

Model	TSF-10	TSF-10F	TSF-11	TSF-11F
Nominal size	15A-25A		25A-50A	
Application	Steam condensate			
Working pressure (Maximum working differential pressure)	TSF-1□□-5: 0.01-0.5 MPa (0.5 MPa) TSF-1□□-10: 0.01-1.0 MPa (1.0 MPa) TSF-1□□-21: 0.01-2.1 MPa (2.1 MPa)			
Max. temperature	220°C			
Material	Body	Ductile cast iron		
	Float	Stainless steel		
	Valve, valve seat	Stainless steel		
Connection	JIS Rc screwed NPT screwed	JIS 10K FF flanged JIS 20K FF flanged	JIS Rc screwed NPT screwed	JIS 10K FF flanged JIS 20K FF flanged
Flow direction	All directions *			

* For installation posture, see 3 of "7.2 Precaution for installation" on Page 8.



Caution

Please confirm that the indications on the product correspond with the specifications of the ordered product model before use.

* If they are different, do not use the product and contact us.

4. Dimensions and Weights

1. TSF-10 and TSF-11 Connection: JIS Rc screwed

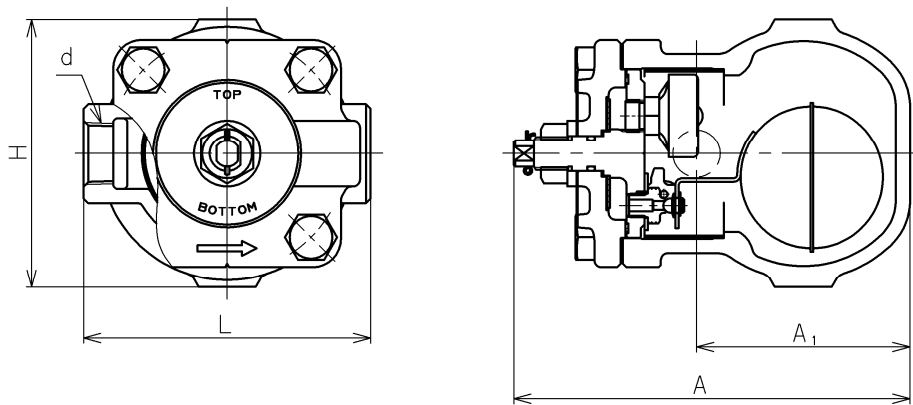

TSF-10

(mm)

Model	Nominal size	d	L	A	A ₁	H	Weight (kg)
TSF-10	15A	Rc 1/2	121	167	90	113	3.6
	20A	Rc 3/4	121	167	90	113	3.6
	25A	Rc 1	145	167	90	113	4.0
TSF-11	25A	Rc 1	190	244	147	186	9.9
	32A	Rc 1 1/4	190	244	147	186	10.0
	40A	Rc 1 1/2	205	244	147	186	10.2
	50A	Rc 2	220	244	147	186	10.5

2. TSF-10F and TSF-11F Connection: JIS 10/20K FF flanged

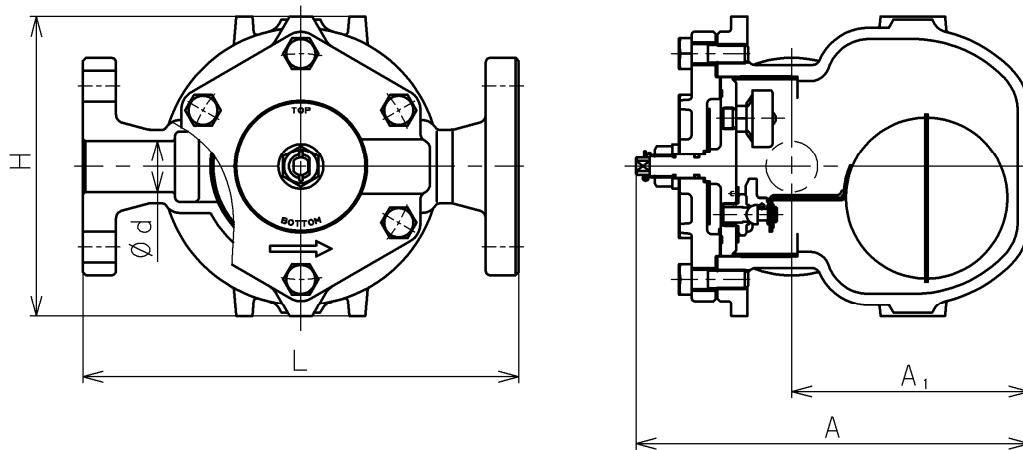

TSF-11

(mm)

Model	Nominal size	d	L	A	A ₁	H	Weight (kg)
TSF-10F	15A	15	175	167	90	113	5.0
	20A	20	195	167	90	113	5.8
	25A	25	215	167	90	113	7.1
TSF-11F	25A	25	270	244	147	186	13.4
	32A	32	270	244	147	186	14.1
	40A	40	280	244	147	186	14.4
	50A	50	290	244	147	186	15.5

5. Operation

1. Start-up of the operation

At start-up, since the float is down, the valve is closed. In this state, air in the system and piping is discharged out through the air vent which is opened. When condensate flows into the product, the float lifts up and opens the valve, and then discharges condensate. Air is continuously discharged out from the air vent.

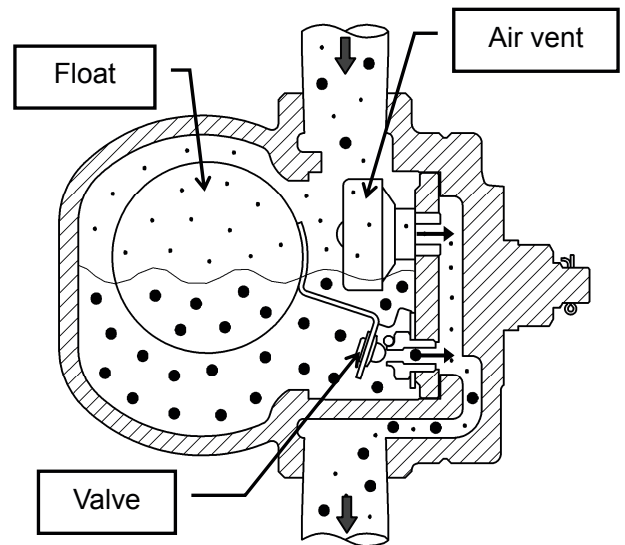

2. Condensate discharging operation

When steam flows into the product, internal pressure of the air vent rises by steam temperature, and the air vent closes. According to the amount of condensate inflow, the float position moves up and down changing the opening degree of the valve, and thus condensate is continuously discharged. The float moves down and the valve closes when condensate inflow stops.

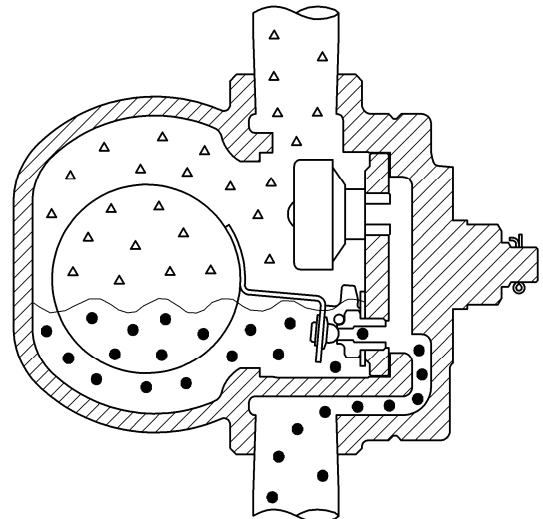

3. Air vent operation

When air or non-condensable gas flows into the product, it accumulates in the upper part of the product. When temperature of air or non-condensable gas decreases with condensate inflow, the air vent opens and discharges it to outside of the product.

Then, operations 2 and 3 repeats according to the inflow amount of condensate and air.

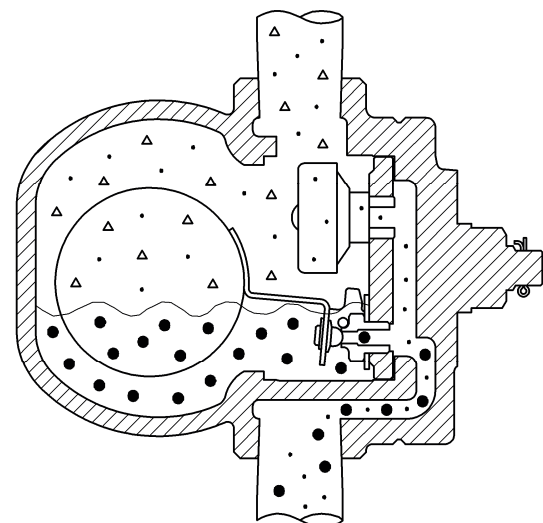

Condensate



Steam



Air

6. Maximum Continuous Discharge Capacity

1. Discharging capability of the steam trap differs by working differential pressure, that is, difference between inlet pressure and outlet pressure (back pressure). In selecting discharge capacity, consider outlet pressure. If inlet pressure is 0.5 MPa and outlet pressure is 0.2 MPa, discharge capacity is of working differential pressure of 0.3 MPa.
2. The discharge capacity shown in the charts below is the maximum value. In designing a system, select a steam trap with a sufficient safety factor (two times the regular level). That is, for example, if a discharge capacity of 500 kg/h is required, select a steam trap capable of discharging more than 1,000 kg/h (maximum discharge).

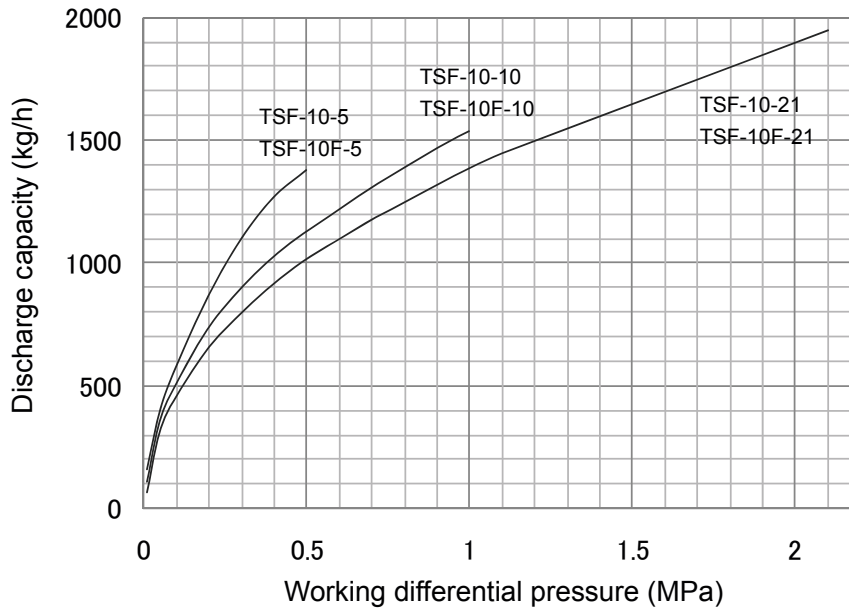

Maximum Continuous Discharge Capacity of TSF-10 and TSF-10F

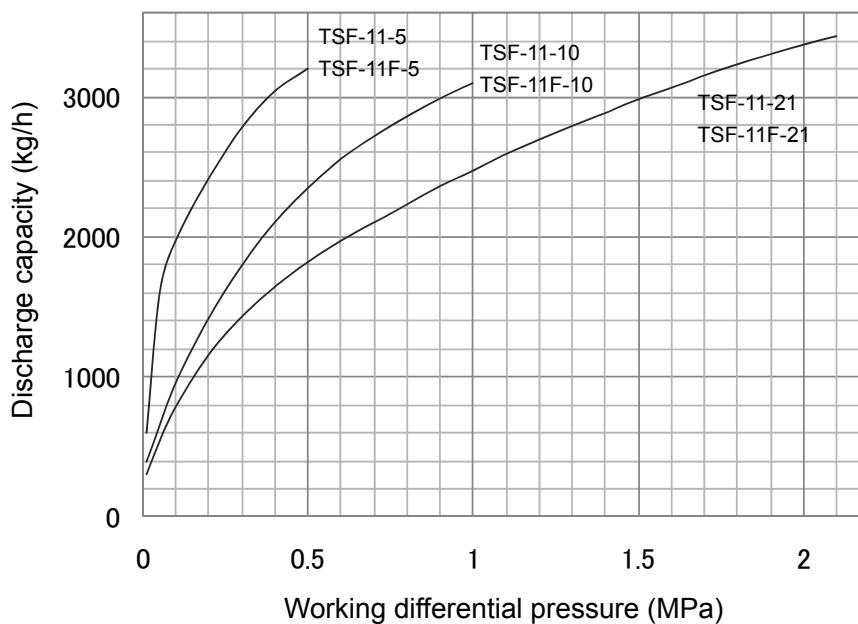

Maximum Continuous Discharge Capacity of TSF-11 and TSF-11F

7. Installation

7.1 Piping example

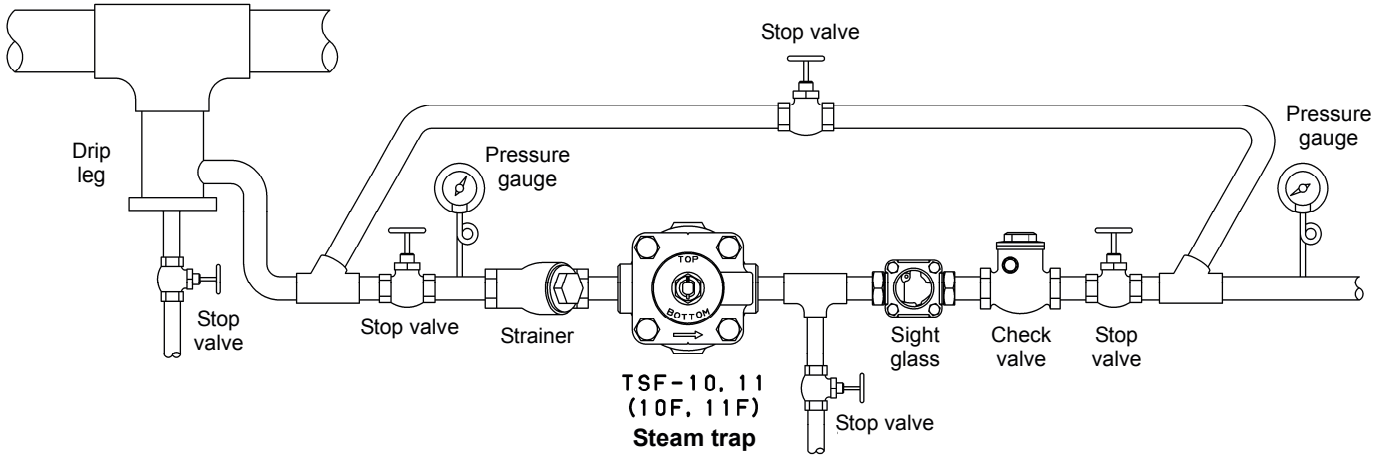

Description	Correct	Incorrect
<p>If the product is installed close to a regulating valve, make sure to install the product at the inlet side of the regulating valve.</p>		
<p>To discharge condensate from the steam main, be sure to install the product so that condensate can be discharged from the bottom of the steam main by drip leg.</p>		

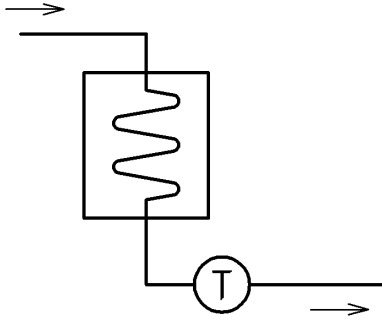
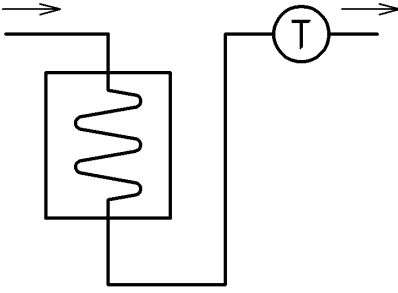
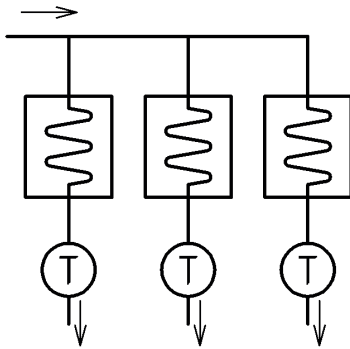
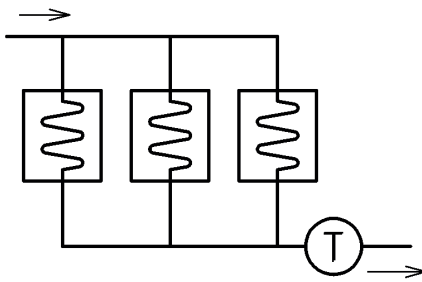
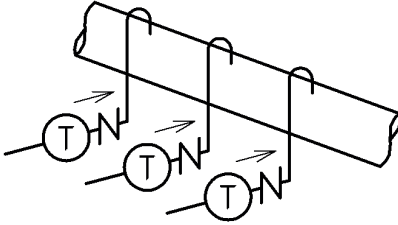
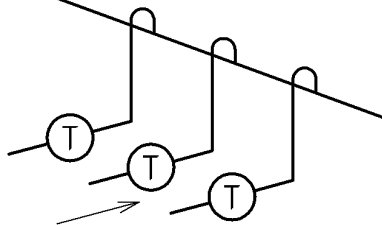
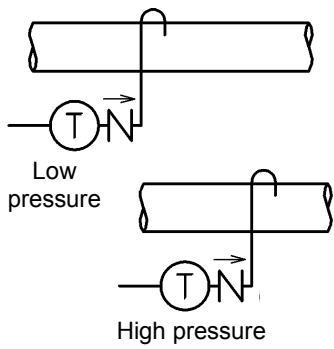
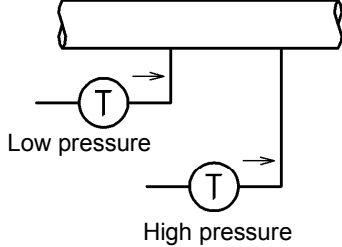
Description	Correct	Incorrect
<p>Install the product below a device which generates condensate.</p>		
<p>Install the products for each device independently.</p>		
<p>The diameter of collecting pipe shall be more than summation of sectional areas of discharge pipes. In addition, install check valves for back flow prevention.</p>		
<p>For condensate recovery, connect the discharge pipe to the upper part of collecting pipe. For traps of different pressure lines, install collecting pipes individually for each pressure. In addition, install check valves for back flow prevention.</p>		 <p>* Re-evaporated steam in high pressure line increases the back pressure of low pressure trap.</p>

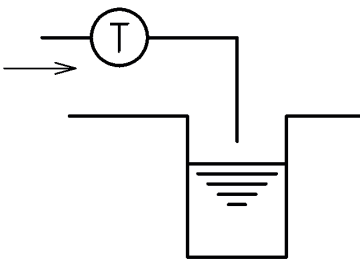
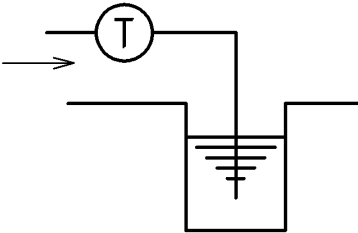
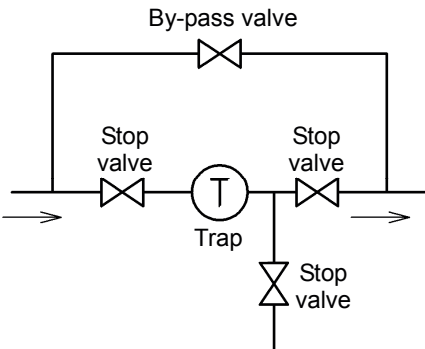
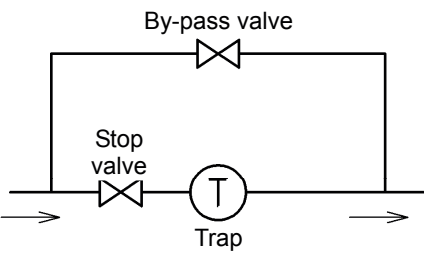
Description	Correct	Incorrect
End portion of discharge pipe shall be off the water surface in the pit.		 <p data-bbox="1015 461 1449 584">* If the discharge pipe is in contact with the water, it absorbs dirty water in the pit and causes malfunction of the product.</p>
Provide a by-pass line around the product, and install stop valves at the outlet side of the product.		

7.2 Precaution for installation

 Caution
<ol style="list-style-type: none"> 1. Before connecting the product to piping, remove foreign substances and scale from the piping. <ul style="list-style-type: none"> * Failure to follow this notice may prevent the product from functioning properly. * To plumb the product, be careful to keep seal materials from entering into the product. 2. To install the product, check the direction of the product so that the fluid flowing and the arrow marked on the product are in the same direction. <ul style="list-style-type: none"> * Setting the product in wrong directions prevents it from functioning properly.

3. Check installation posture.

* Wrong posture hampers proper operation.

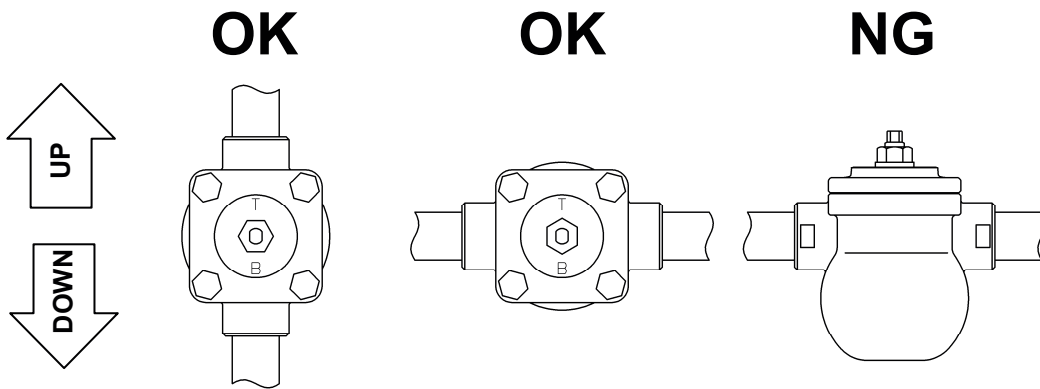

* Allowable tilt from horizontal line is within $\pm 10^\circ$.

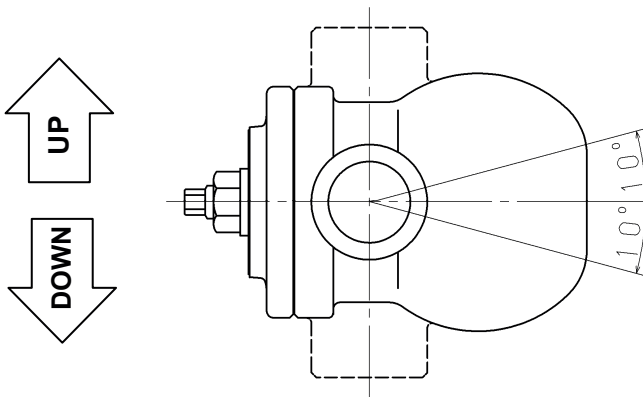

4. Adjust direction of the name plate in no pressure condition after installation.

* Do not turn the cock unless the pressure inside of the product and piping is completely discharged. Forcing the cock to turn may result in damage to the cock.

* Wrong direction hampers proper operation.

* Fix the cock with spanner and loosen the nut. Turn the cock and adjust direction of the name plate to position "TOP" and "BOTTOM" signs on upside and downside respectively.

Fix the cock with spanner and fasten the nut after adjustment.

* Allowable tilt from vertical line is within $\pm 10^\circ$.

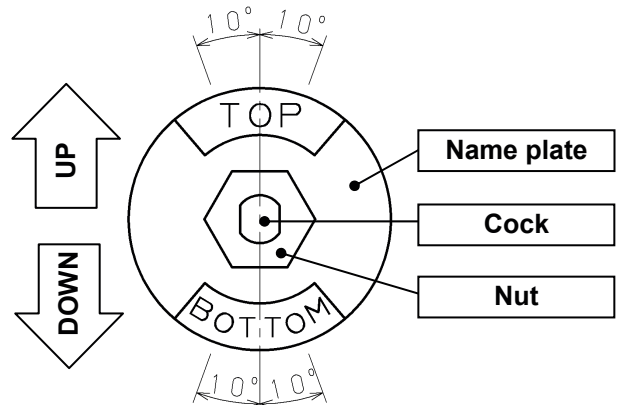

5. Make sure to support the piping immovably.

* If an excessive piping stress is applied, the product may not open or close.

6. Do not disassemble the product unless it is necessary.

* Disassembly may prevent the product from functioning properly.

7. Secure enough space for maintenance (such as cleaning of strainer), inspections and repair as shown below.
 * Failure to follow this notice prevents maintenance, inspection and repair.

TSF-10•10F

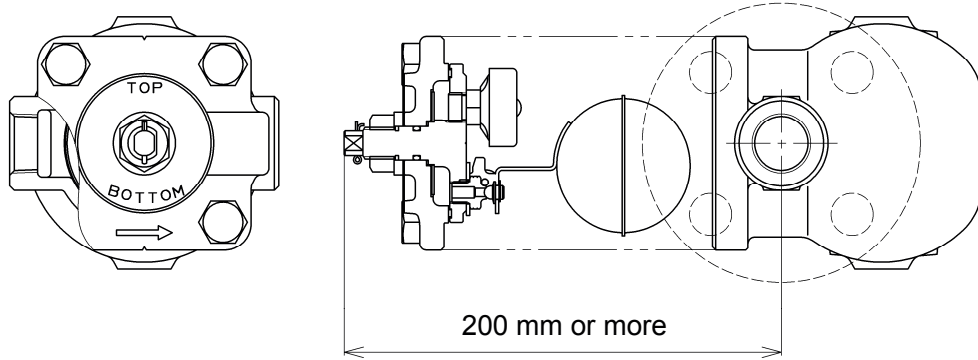

TSF-11•11F

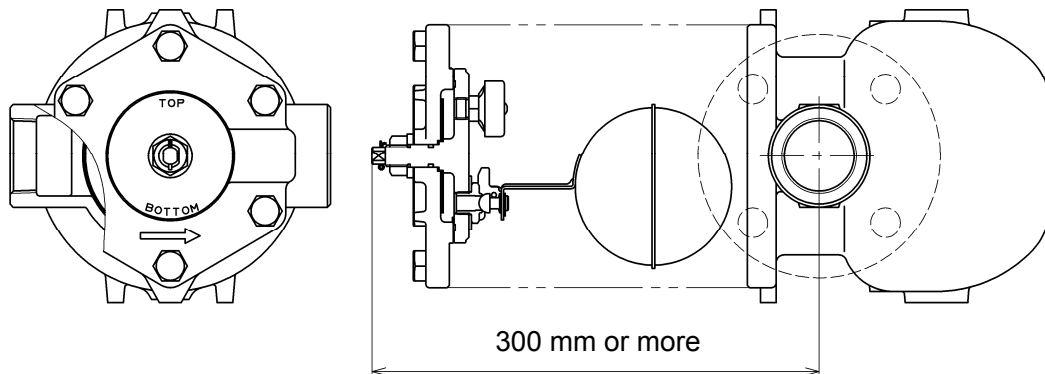

8. Slope the piping and place the product at as a low position as possible in order to make condensate flow into the product by its own weight.
9. To install the product in a main steam pipe, provide a drip leg at the inlet side of the product.
10. Install a strainer (mesh size of 80 or more is recommended) at the inlet side of the product.
11. Install the product so that it is not subjected to the shock of water hammer. Do not install a quick operating valve before and/or after the product.
 * Failure to follow this notice may result in malfunction due to damage to the float, or may result in scalds or injury due to blow off when the product is subjected to an excessive shock and damaged.
12. Install a bypass line.
 * The system has to stop operation while inspection and maintenance of the product if the bypass line is not installed.

8. Operating Procedure

8.1 Precaution for operating procedure



Warning

1. Before leading fluid, make sure that the product is securely connected to piping and that there is no loose.
 - * Failure to follow this notice may result in scalds or injury due to blow-off.
2. Do not touch the product with bare hands while the product operates.
 - * Failure to follow this notice may result in scalds.
3. Do not stand in front of the outlet opening of the product while the product operates.
 - * Failure to follow this notice may result in scalds or injury due to blow-off.



Caution

1. Slowly open each stop valve to prevent water hammer.
 - * Opening stop valves quickly may result in damage to other equipments due to hunting or water hammer.
2. Do not turn the cock while the product operates.
 - * Do not turn the cock unless the pressure inside of the product and piping is completely discharged. Forcing the cock to turn may result in damage to the cock.
 - * Wrong direction of the cock hampers proper operation.

9. Maintenance

9.1 Precaution for maintenance



Warning

1. Do not touch the product with bare hands.
* Failure to follow this notice may result in burns.
2. Completely discharge internal pressure of the product, piping and equipment, and cool down the product prior to disassembly or maintenance.
* Failure to follow this notice may result in scalds or injury due to residual pressure.



Caution

1. Conduct daily inspection in order to maintain the optimal performance of the product.
* Failure to follow this notice may prevent the product from functioning properly.
* See “9.3 Troubleshooting” on Page 13 if trouble is observed.
2. After leaving the product not operated for a long period, perform inspection before start-up of operation.
* Failure to follow this notice may cause malfunction due to rust inside of the product and piping.
3. Put a container under the product at disassembly since condensate may flow out.
* Failure to follow this notice may result in making the surroundings dirty.
4. Be careful not to drop the parts at the time of disassembly. The disassembled parts should be placed on soft cloth in order to avoid scratches and damage.
* Damage on the parts may cause malfunction and affect the optimal performance.
5. To assemble, connect all the parts securely and tighten the bolts uniformly in diagonal order.
* Failure to follow this notice may cause malfunction or outside leakage.
6. When repairing, do not use the parts other than the dedicated parts manufactured by Yoshitake. Do not modify the product.
* Failure to follow this notice may cause damage to the product, or may result in scalds or injury due to blow-off or malfunction.
7. In case of problems due to foreign substances or scale, the product needs repair or part replacement. Please contact us for details.
(Please note that any repair due to foreign substances or scale in the product is subject to a charge even during the warranty period.)

9.2 Daily and periodic inspections

Conduct daily and periodic inspections in order to maintain the optimal performance of the product. See "9.3 Troubleshooting" on Page 13 for the remedies if trouble is observed.

- Daily inspection (once a day)

Conduct daily inspection during operation of the product.

Items	Standards for Inspection
Discharge condition of condensate	Condensate is discharged smoothly.
Outside leakage	No outside leakage of condensate or steam.

- Periodic inspection (once a year)

Conduct disassembly inspection periodically.

Items	Standards for Inspection
Seat surfaces of the valve and valve seat	No scratch, abrasion, or foreign substances on seat surfaces.
Shape of float (P)	No deformation or damage on the float (P)
Dirt on the screen	No clogging on the screen

9.3 Troubleshooting

Trouble	Cause	Remedy
Condensate is not discharged.	1. Blockage of foreign substances in a discharge hole of the valve seat.	1. Disassemble and clean it.
	2. The screen is clogging.	2. Disassemble and clean it.
	3. The float (P) is damaged.	3. Replace it with a new one.
	4. Breakage as a result of abnormal pressure rising due to freezing or water hammer, etc.	4. Replace the product with new one and use it within the working pressure range.
	5. Steam locking.	5. Change the piping system layout.
	6. "TOP" and "BOTTOM" signs on the name plate are in wrong positions.	6. Adjust direction of the name plate to position "TOP" and "BOTTOM" signs on upside and downside respectively. * See Caution No. 4, "7.2 Precaution for installation" on Page 8.
Continuous blowout.	1. Foreign substances stuck on valve, valve seat or air vent (P).	1. Disassemble and clean them.
	2. Abrasion or scratches on the valve, valve seat or air vent (P).	2. Replace the parts with new ones.
	3. Insufficient capacity of the product.	3. Replace the product with another model of sufficient capacity.
	4. "TOP" and "BOTTOM" signs on the name plate are in wrong positions.	4. Adjust direction of the name plate to position "TOP" and "BOTTOM" signs on upside and downside respectively. * See Caution No. 4, "7.2 Precaution for installation" on Page 8.
Steam leakage.	1. Leakage due to loosening of the bolt.	1. Replace the cover gasket with new one, and retighten the bolt.
	2. Leakage due to deterioration of cock gasket (P2) and O-ring.	2. Replace the parts with new ones.
	3. Leakage as a result of abnormal pressure rising due to freezing or water hammer, etc.	3. Replace the product with new one and use it within the working pressure range.

9.4 Exploded drawing

The parts shown in the rectangle boxes are available as consumable supply.

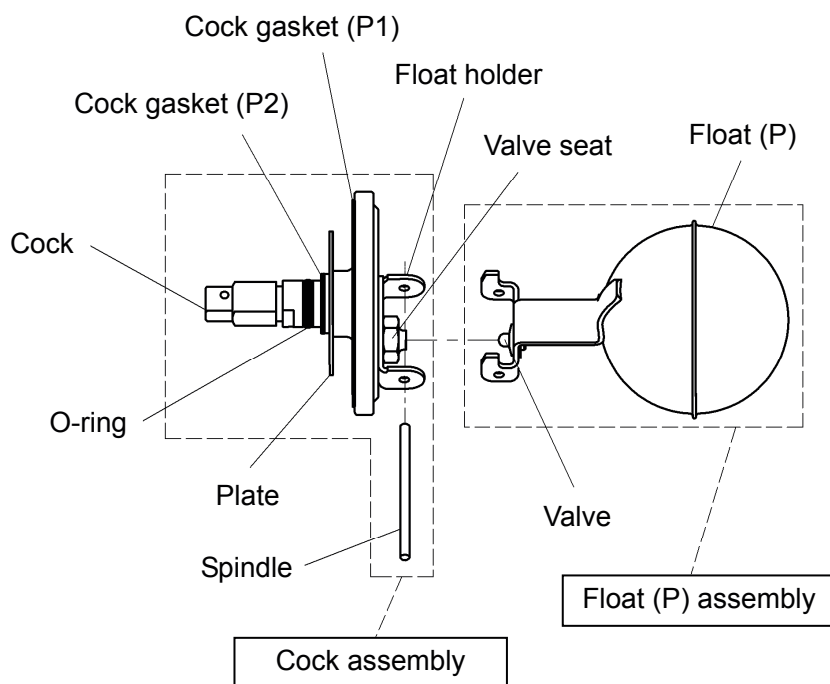
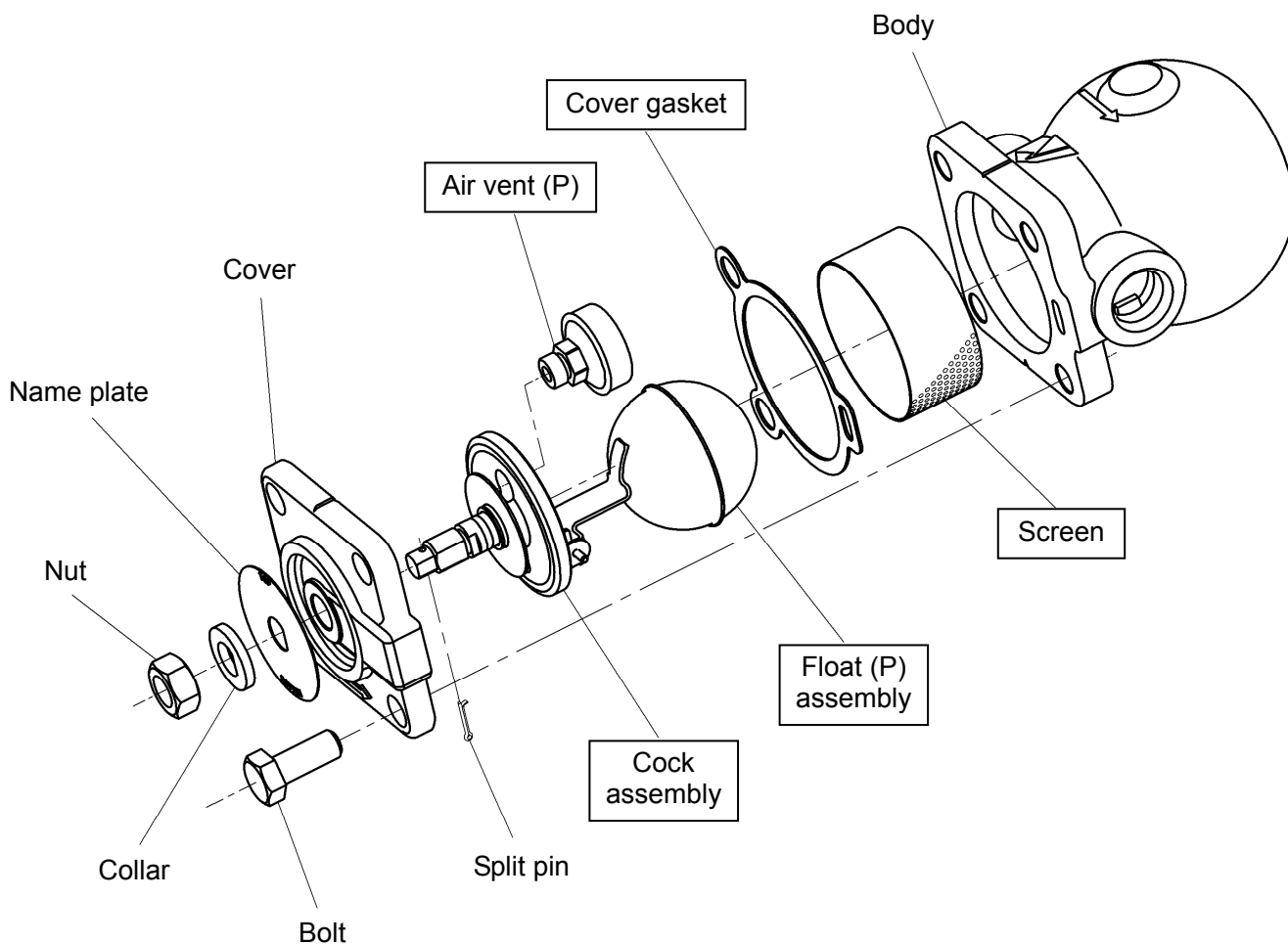

9.5 Disassembly

- Tools to be used

Name of tool	Size (Nominal size)
Spanner	5/8 inch (16 mm), 22 mm
Ring wrench	19 mm

- [Procedure 1] Loosen the bolts fixing the cover with ring wrench (width across flat: 19 mm), and remove the cover and gasket from the body. Pull out the screen from the body.

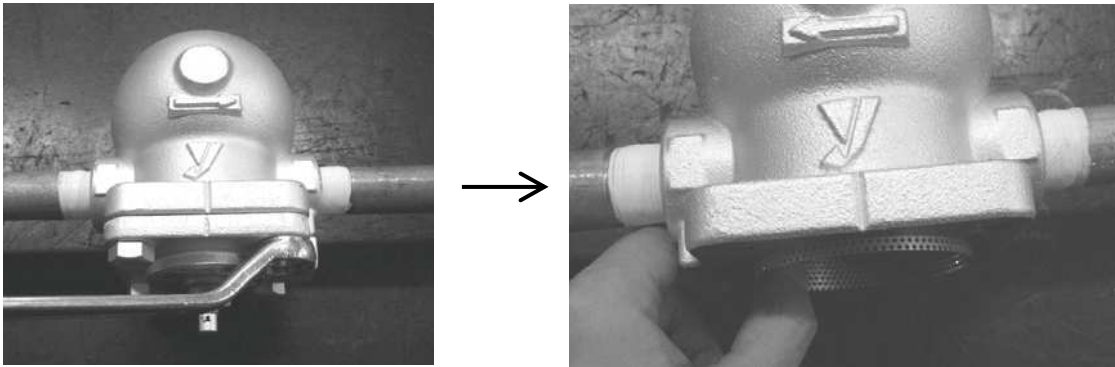

- [Procedure 2] Pull out the spindle from the float holder and remove the float (P) assembly.

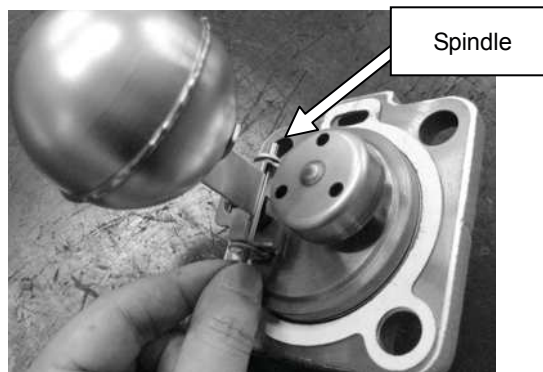

- [Procedure 3] With fixing the cock (width across flat: 9 mm), remove the air vent (P) with spanner (width across flat: 5/8 inch).
* To fix the cock, use a fixing device such as vise bench.

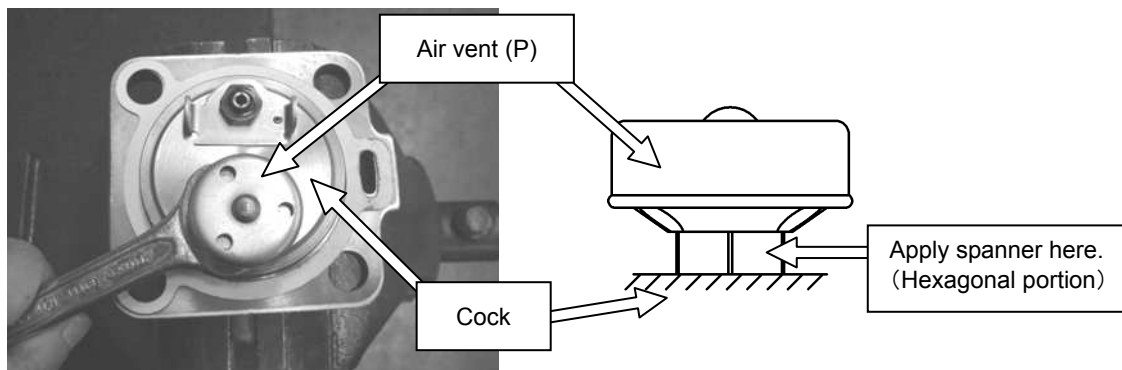

[Procedure 4] Remove the split pin from the cock. With fixing the cock (width across flat: 9 mm), remove the nut by using spanner (width across flat: 22 mm), and then remove the collar and the name plate.



[Procedure 5] By pulling out the cock from the cover, the cock assembly can be replaced.

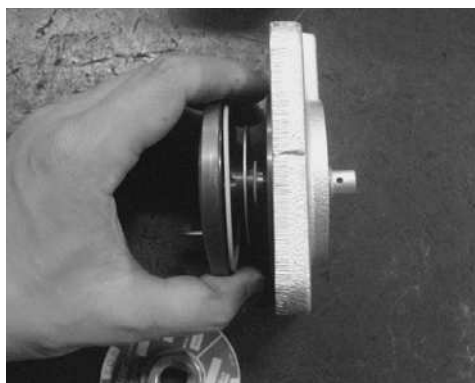

9.6 Reassembly

- Tools to be used

Name of tool	Size (Nominal size)
Torque Wrench	* Tightenable with torque of 35 N·m Width across flat: 19 mm
Torque Wrench	* Tightenable with torque of 35 N·m, Open-head type Width across flat: 22 mm, 5/8 inch (16 mm)
Spanner	9 mm
Ring Wrench	22 mm

[Procedure 1] Check that the cock gasket (P1), plate, cock gasket (P2) and O-ring (P11) are attached to the cock. Apply lubricant agent to the cock gasket (P1) at its contacting surface with the cock (Recommendation: SOLVEST No.110 paste, STT Inc.). Apply fluoro grease to the O-ring (Recommendation: SOLVEST No.245, STT Inc.).

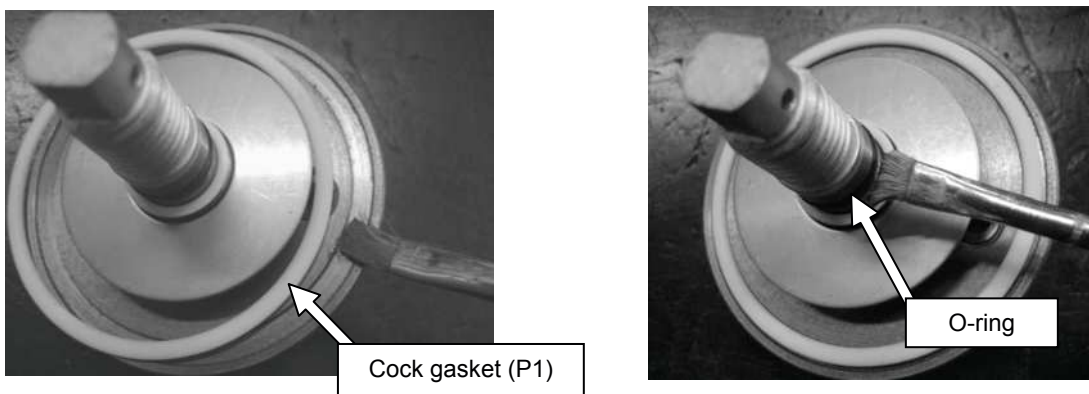

[Procedure 2] Attach the cock (after taking Procedure 1) to the cover. Check that the cock gasket (P1) is attached to the cock properly. If not, it may cause steam leakage to the outlet side.

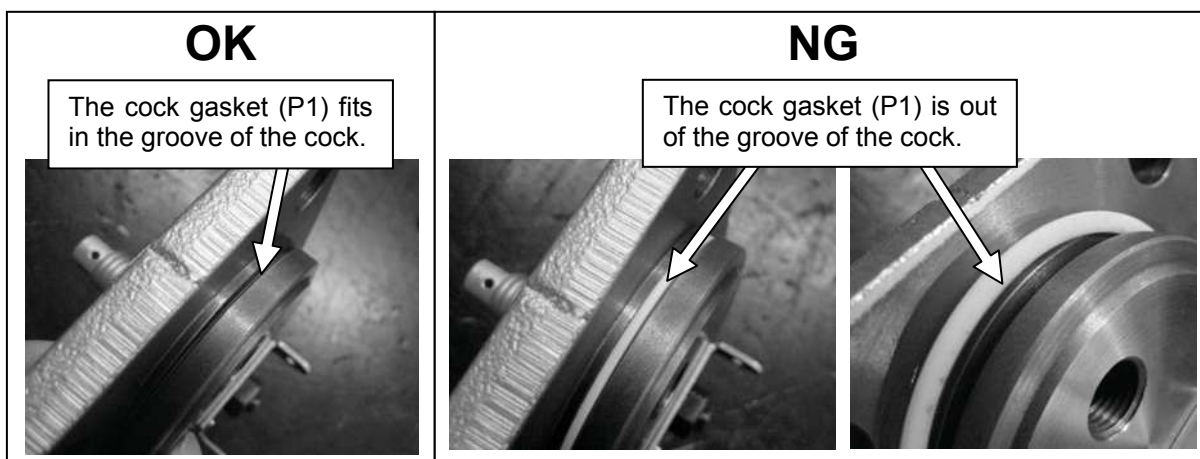

- [Procedure 3] Attach the name plate, collar, and nut to the cock.
 * When installing, match the holes on the name plate and collar with shape of the cock.

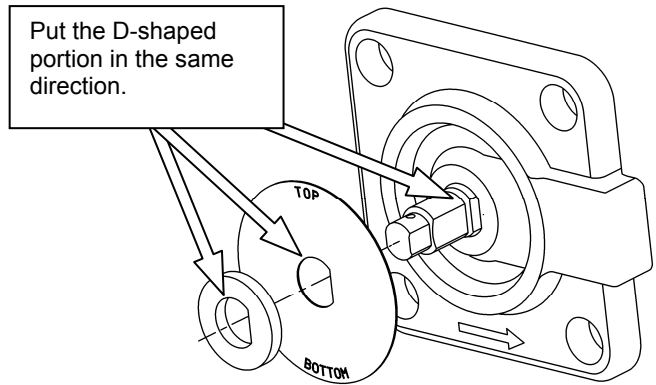

- [Procedure 4] With fixing the cock (width across flat: 9 mm), tighten the air vent (P) with torque wrench (width across flat: 5/8 inch, open-head type) with torque of 35 N·m. Apply liquid gasket to the threaded area of the air vent (P) (Recommendation: TB1209, ThreeBond Co., Ltd.).
 * To fix the cock, use a fixing device such as vise bench.

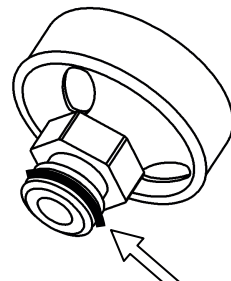
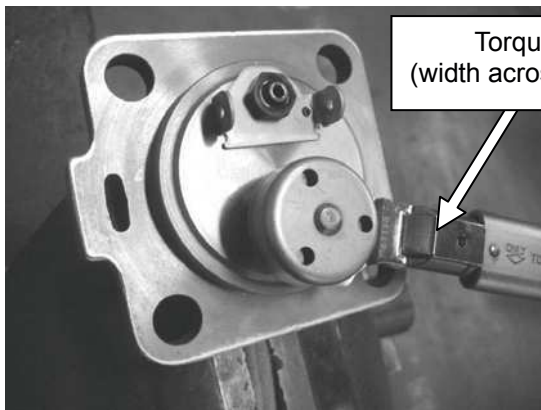

- [Procedure 5] Connect the float holder and float (P) assembly with the spindle. Check that the float (P) assembly moves smoothly, and that the seat surface of the valve is in contact with that of the valve seat.

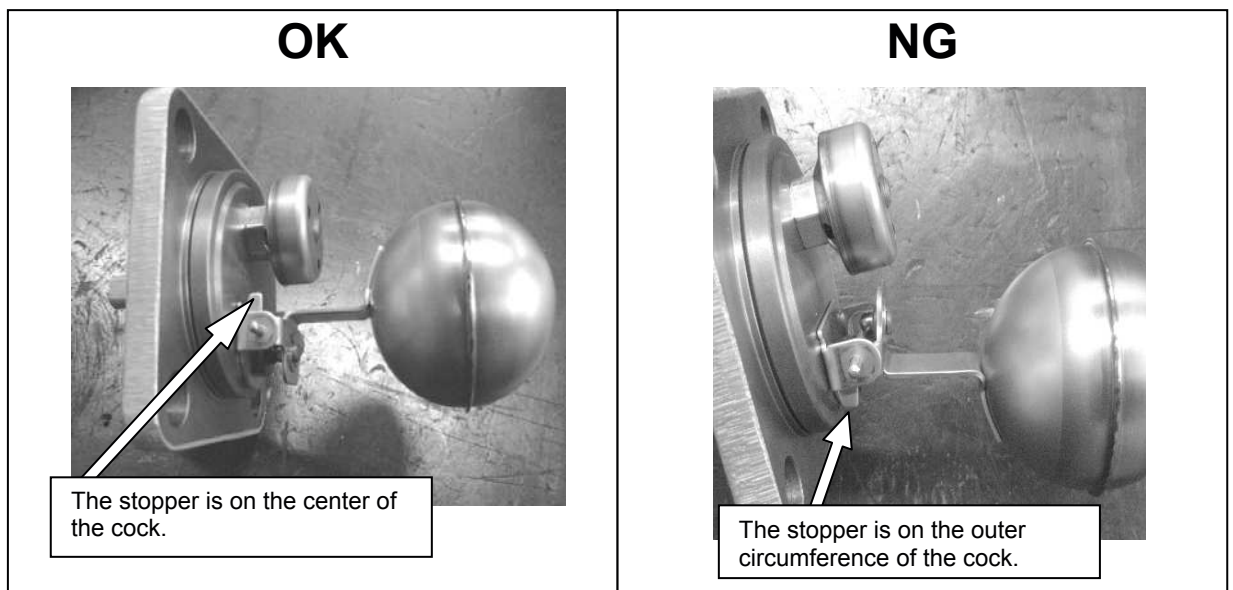

[Procedure 6] Attach the screen to the body. The screen can be inserted from either end.

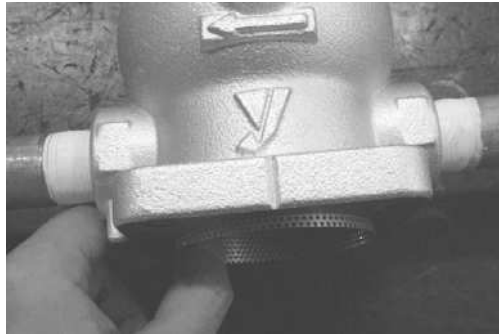

[Procedure 7] Install the cover gasket to the cover. Make the oval-shaped holes on the cover and on the cover gasket in the same position. Make sure to use a new cover gasket. Do not apply lubricant agent to the cover gasket.

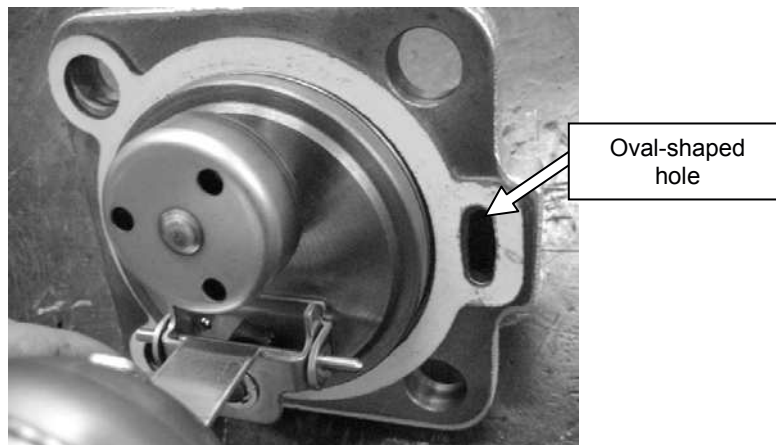

[Procedure 8] Install the cover to the body. Tighten the bolt with torque wrench (width across flat: 19 mm) with torque of 35 N·m.
* Do not use impact wrench to tighten the bolt. Using it may cause unevenly tightened bolt or damaged gasket, resulting in outside leakage of condensate or steam.

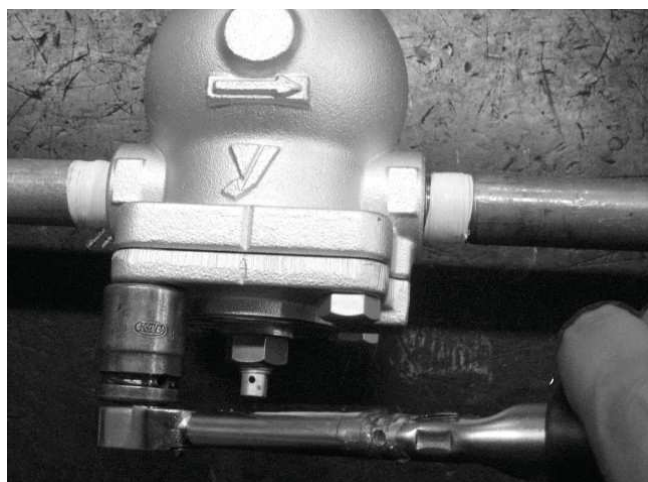

[Procedure 9]

With applying spanner to the cock (width across flat: 9 mm), adjust the direction of the name plate. After adjustment, tighten the nut with torque wrench (width across flat: 22 mm) with torque of 35 N·m.
* If the name plate is not in correct direction, the product does not work properly. See “No.4, 7.2 Precaution for installation” on Page 8 for the adjustment procedure.

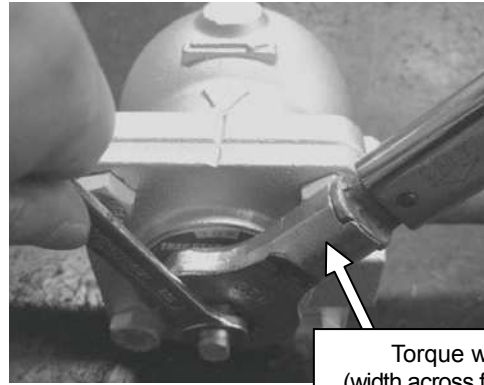

Torque wrench
(width across flat: 22 mm)

9.7 Parts replacement procedure

Part name	Disassembly (See 9.5.)	Reassembly (See 9.6.)
Cover gasket	Procedure 1	Procedures 7 to 8
Float (P) assembly	Procedures 1 to 2	Procedures 5 to 8
Air vent (P)	Procedures 1 to 3	Procedures 4 to 8
Cock assembly	Procedures 1 to 5	Procedures 1 to 9
Screen	Procedure 1	Procedures 6 to 8